



RapidRF Smart LDMOS Front-End Designs

RAPIDRFSL-FRONTEND

Last Updated: May 23, 2023

NXP's RapidRF Smart LDMOS front-end designs provide further integration with a highly efficient RF power amplifier, linear pre-driver, Rx LNA with T/R switch, and a circulator all in a compact footprint—and now includes the bias controller and temperature sensor within the power amplifier package. These designs incorporate a coupler for DPD feedback and are to be used with digital pre-distortion.

RapidRF reference boards are ideal for 5G radio units requiring 2.5 to 8 Watts (34-39 dBm) average transmit power at the antenna. A common PCB layout used for multiple frequency bands simplifies both design and manufacturing for faster time-to-market.

RapidRF Smart LDMOS Front-End Block Diagram Block Diagram

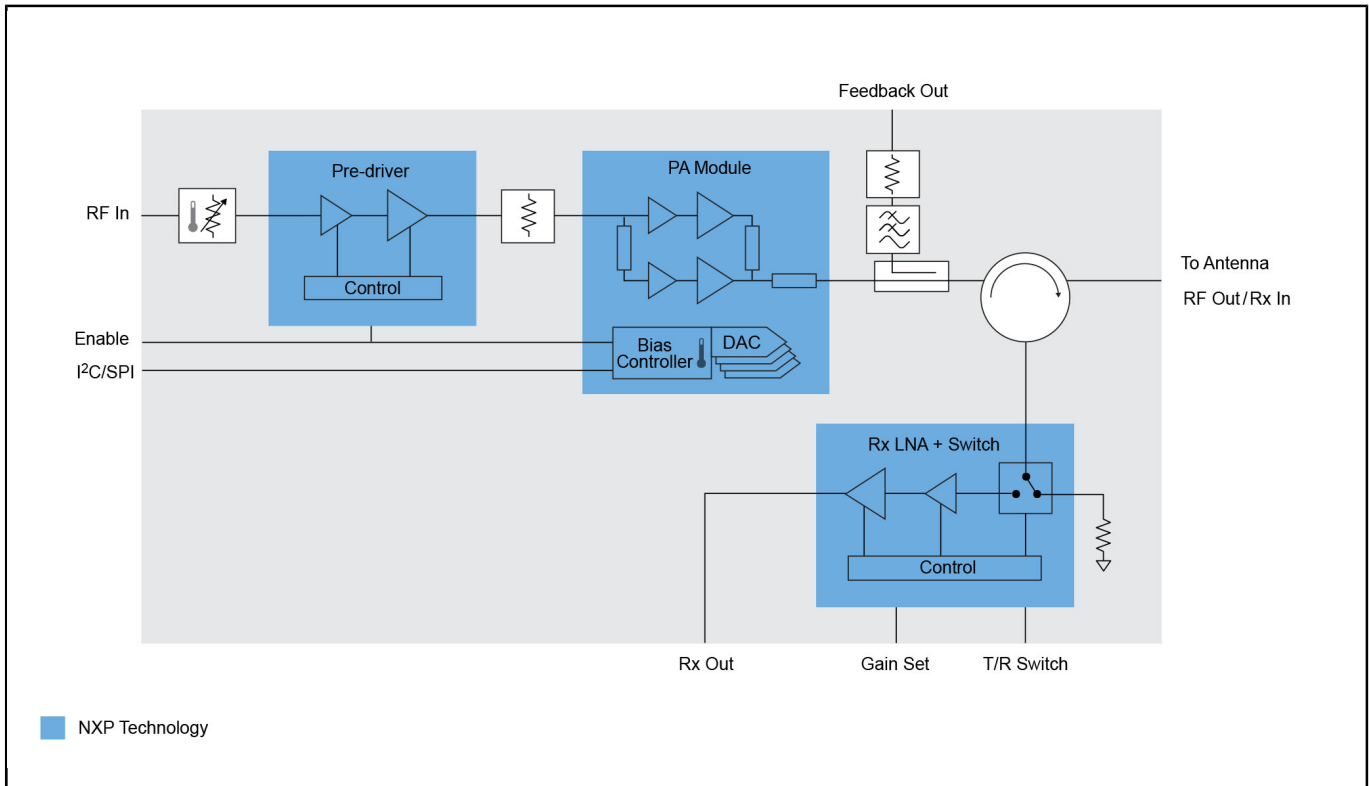

View additional information for [RapidRF Smart LDMOS Front-End Designs](#).

Note: The information on this document is subject to change without notice.

www.nxp.com

NXP and the NXP logo are trademarks of NXP B.V. All other product or service names are the property of their respective owners. The related technology may be protected by any or all of patents, copyrights, designs and trade secrets. All rights reserved. © 2024 NXP B.V.