



1800–2200 MHz Advanced Doherty Alignment Module

MMDS20254H

Last Updated: May 3, 2024

The MMDS20254H is an advanced Doherty alignment module (ADAM), a new class of highly integrated GaAs MMIC control circuits designed specifically to optimize the performance of today's Doherty amplifiers. ADAM provides the ability to align and optimize the RF performance in the carrier and peaking paths of a Doherty amplifier, thus providing improved overall BTS performance. When combined with Airfast® power transistors, this sophisticated technology provides increased manufacturing yields and power added efficiency. Available for frequency bands spanning 700 MHz to 2700 MHz. Advantages:

- Production yield improvement and tighter parametric distributions
- Enables significant Doherty bandwidth improvement
- Optimized performance over the entire cellular frequency band
- Improved DPD correction with tighter performance distributions
- Increased system efficiency (across entire frequency band)
- Smaller output devices can be used, system efficiency is increased
- Enables consistent asymmetric Doherty with different transistors (works with symmetric Doherty as well)
- Field adjustment possible to optimize power amplifier performance under different conditions (power level, supply voltage, temperature)

RF Control Circuit ADAM Block Diagram Block Diagram

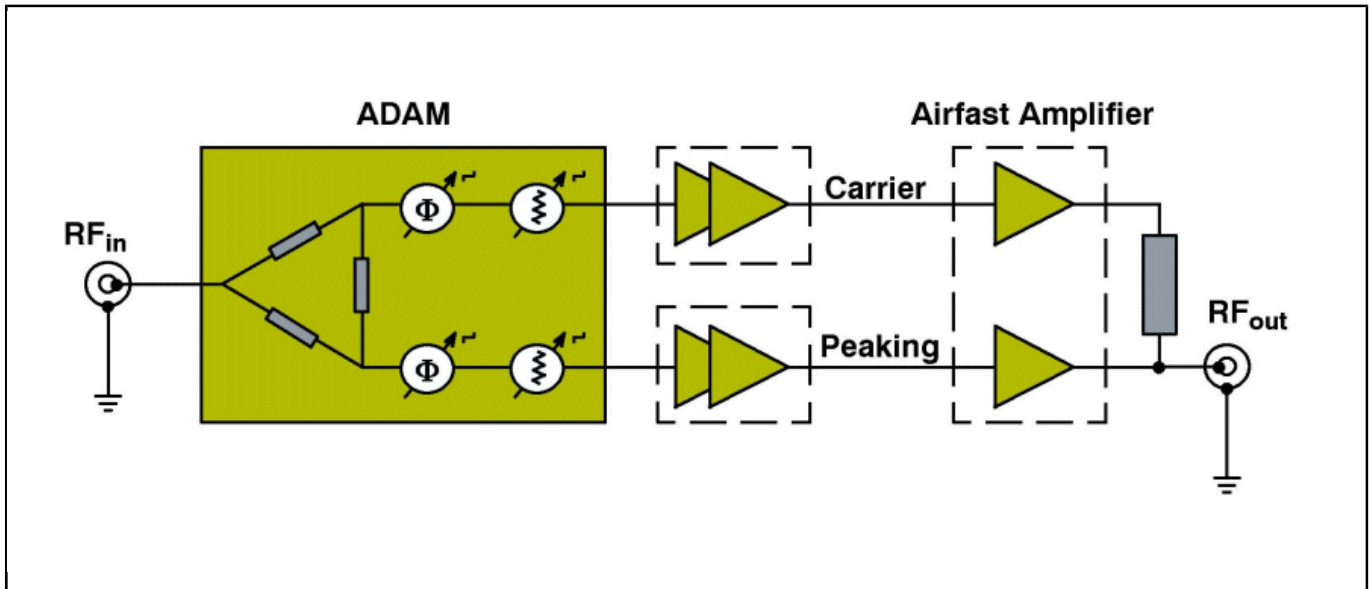

View additional information for [1800-2200 MHz Advanced Doherty Alignment Module](#).

Note: The information on this document is subject to change without notice.

www.nxp.com

NXP and the NXP logo are trademarks of NXP B.V. All other product or service names are the property of their respective owners. The related technology may be protected by any or all of patents, copyrights, designs and trade secrets. All rights reserved. © 2024 NXP B.V.